

# DADF-D1 Installation Procedure

Follow the instructions in this booklet when installing the DADF to its host machine.

## 1. Unpacking and Checking the Contents

Unpack the shipping box, and check its contents:

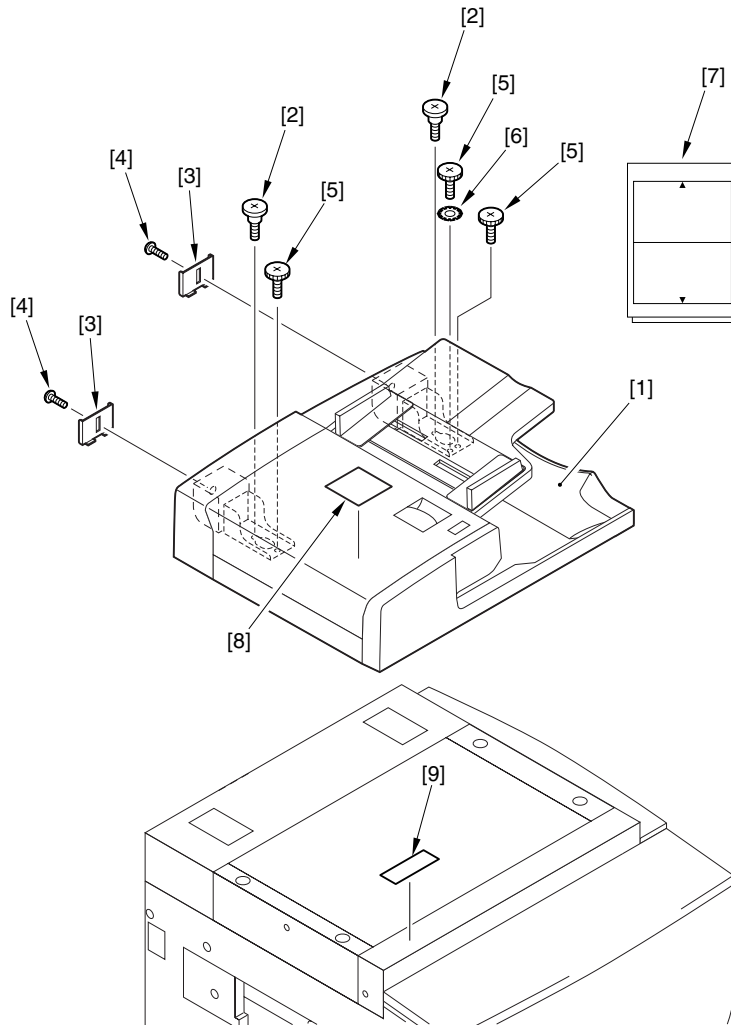

Figure 1-1

- [1] DADF ..... 1 unit
- [2] Stepped screw ..... 2 pc.
- [3] Angle guide plate ..... 2 cp.
- [4] Binding screw (Mx6) ..... 2 pc.
- [5] Thumb screw ..... 3 pc.
- [6] Washer ..... 1 pc.
- [7] Test chart ..... 2 sheets
- [8] Label ..... 1 pc.\*
- [9] Label ..... 1 pc.

\*: Europe only.

## 2. Installing to the Host Machine

Be sure to observe the following when installing the DADF to its host machine:

1. The host machine must have properly been installed.
2. The power plug of the host machine must remain disconnected during the work.
3. The screws must be identified by type (length, diameter) and location.
4. The washer, where used, must always be used to protect against static electricity.

- 1) Turn off the host machine.
- 2) Fit two stepped screws [1] to the host machine.

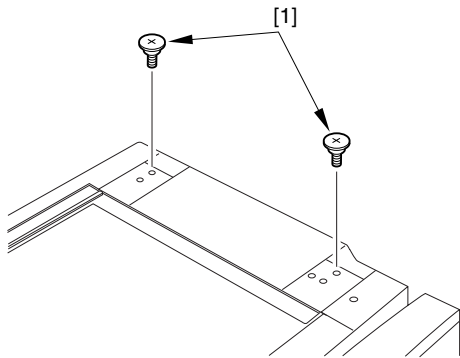

Figure 2-1



When sliding, take care not to trap the rubber cover at the rear of the hinge.

- 3) Fit the stepped screws in the larger holes of the hinges of the DADF, and slide the DADF to the front.

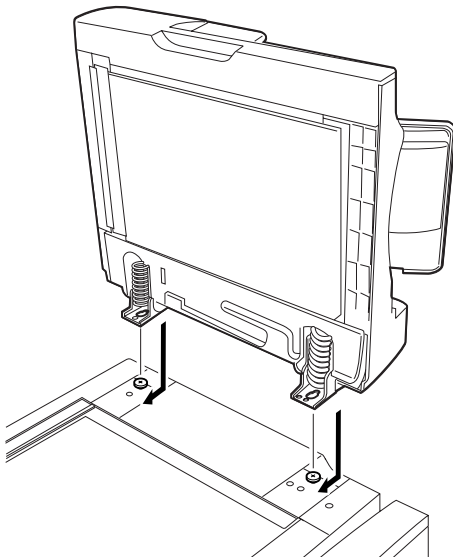

Figure 2-2

- 4) Fit the three thumb screws [1] and the washer [2], and secure the DADF to its host machine.

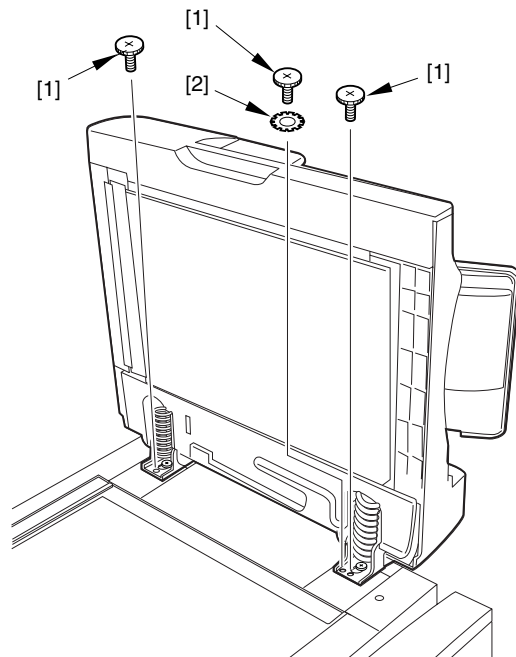

Figure 2-3

- 5) Connect the interface cable [1] of the DADF to its host machine.

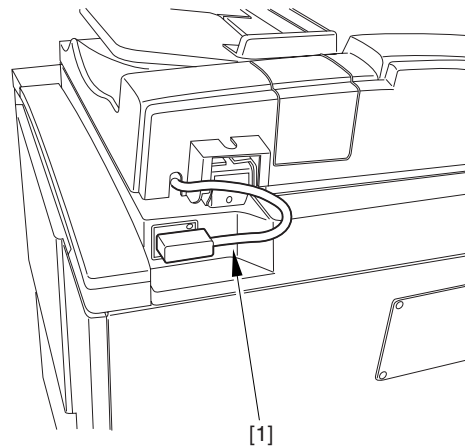

Figure 2-4

### 3. Label

#### 1) How to Attach the Label to the Reader Unit

- iR1600/2000

Attach the label by placing its top 5mm away from the bottom of the glass and aligning its left with the left end of the glass.

- iR2200/2800/3300

Attach the label by placing its top 10mm away from the bottom of the glass and aligning its left with the left end of the glass.

- iR5000/6000/7200

Attach the label by placing its top 35mm away from the bottom of the glass and aligning its left with the left end of the glass.



If the label overlaps with the screw blanking hole, shift the label attachment position to the front until the label does not overlap with the hole.

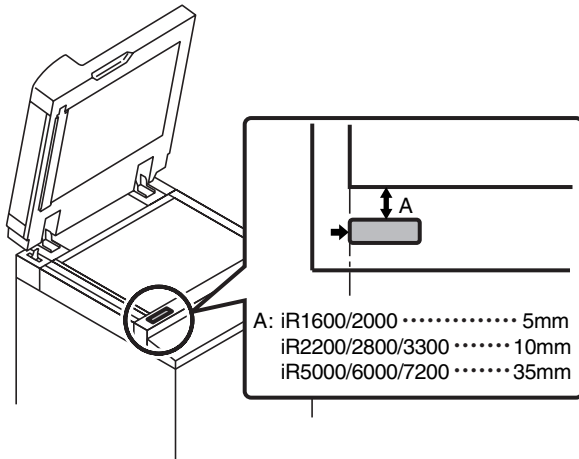

Figure 3-1

#### 2) How to Attach the Label (FC3-1027) to the DADF-D1

Attach the label by aligning its top with the rear edge of the recess on the open/close panel and placing its left 15mm away from the left end of the open/close panel

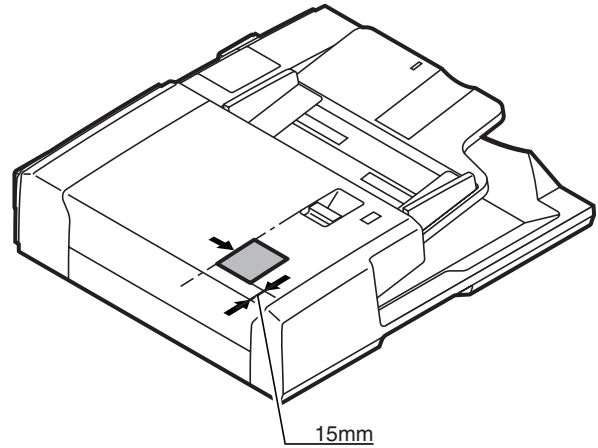

Figure 3-2

## 4. Making Adjustments after Installation

Connect the power plug, and turn on the main switch; then, perform the following in sequence:

### 4-1 Removing the Slant



Be sure to keep the DADF open whenever turning the hex bolt [2].

- 1) Loosen the nut [1] found at the rear of the left hinge, and turn the hex bolt [2] clockwise (viewing it from the rear) until you start to feel resistance. For the position of the fixing member [3], refer to the marking line [4].
- 2) Tighten the nut [1].

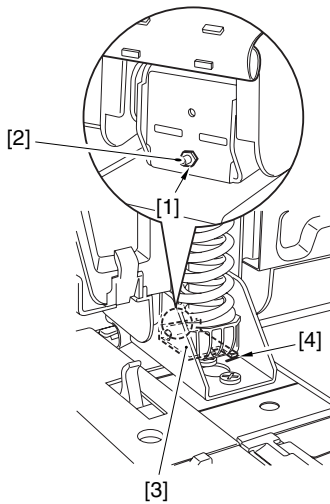

Figure 4-1

### 4-2 Adjusting the Height of the DADF

- 1) With the DADF closed, check to make sure that the height adjusting member [1] at the left front/rear is in contact with the reading glass [2].

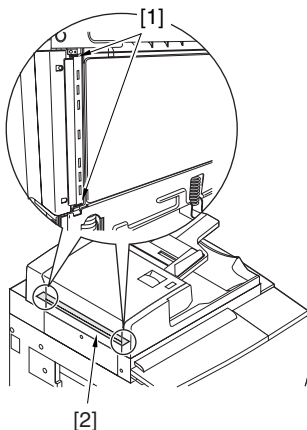

Figure 4-2



To facilitate the check, turn on the scanning lamp by making the following in service mode of the host machine: COPIER>FUNCTION>MISC-R>SCANLAMP. However, be sure to turn it off within 5 min.

### [If the Adjusting Member Is Not in Contact]



You need not turn the fixing screw found at the top of the right hinge.

- 1) If the height adjusting member at the left front/rear is not in contact with the reading glass, turn the fixing screw [1] found at the top of the left hinge as follows to make adjustments:
  - If the adjusting member is not in contact at the front, turn the fixing screw [1] clockwise.
  - If the adjusting member is not in contact at the rear, turn the fixing screw [1] counterclockwise.

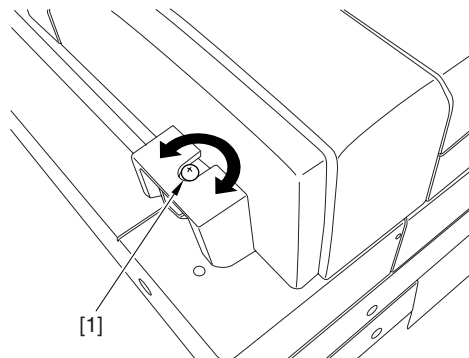

Figure 4-3

### 4-3 Adjusting the DADF Orthogonal Angle

The following adjust the orthogonal angle (right angle) between the scanner of the host machine and the DADF's original feed path:

- 1) Select the A4 or LTR Test Chart supplied according to a paper size to be used by a user.

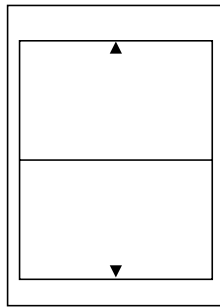

Figure 4-4

- 2) Place the Test Chart [1] on the original tray, and make a print in Direct.

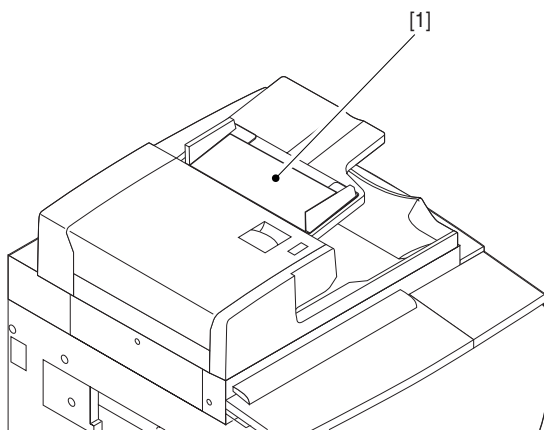

Figure 4-5

- 3) Place the test chart over the output obtained in step 2), and check the orthogonal angle of the images.

$$A \leq 1 \text{ mm}$$

$$B \leq 1 \text{ mm}$$



Be sure to refer to the line along the leading edge of the sheet:

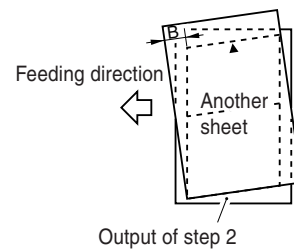
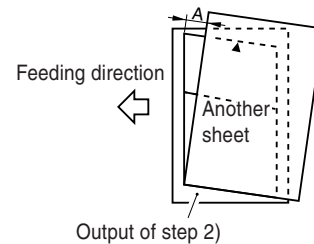

Figure 4-6

If the Angle Is Not as Indicated

- 1) Loosen the two thumb screws [1] at the front of the right hinge unit.
- 2) Turn up the rubber cover [2] at the rear of the right hinge unit, and loosen the fixing nut [3]; then, turn the hex bolt [4] to adjust.

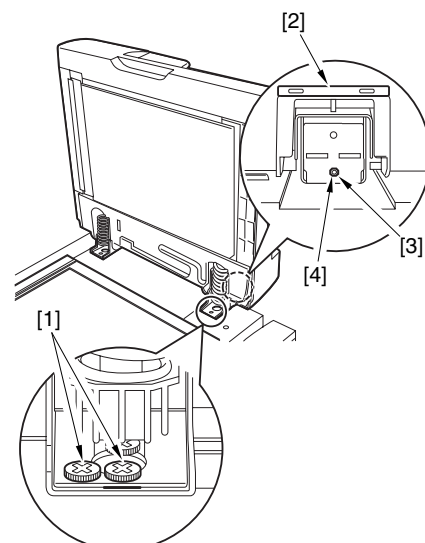
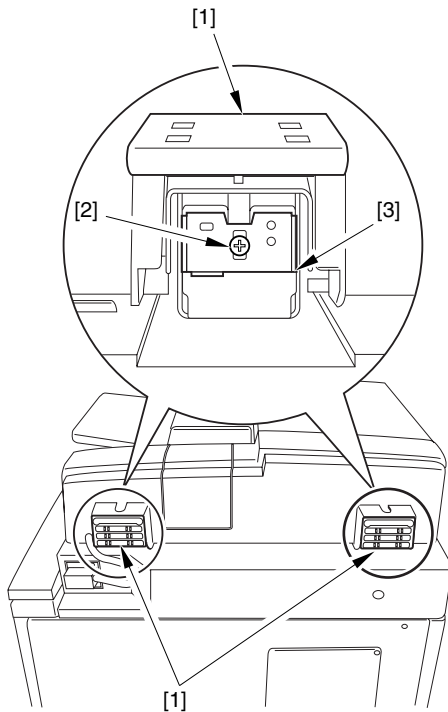

Figure 4-7



Be sure to keep the DADF open when turning the adjusting screw.

- 3) After making the adjustments, tighten the nut [2] to secure the hex bolt [3]; then, tighten the two thumbscrews [1].
- 4) Once again, print the test chart to make sure that the image is as indicated.
  - If  $A > 1$  mm, turn the bolt [3] counterclockwise.
  - If  $B > 1$  mm, turn the bolt [3] clockwise.
- 5) Turn up the rubber cover [1], and mount the angle guide plate [3] to the left/right hinge with two screws [2] each.



**Figure 4-8**

#### 4-4 Adjusting the Read Position

The following adjusts the read position of the host machine in relation to the read position of the DADF:

- 1) Press the ' $\otimes$ ' key, '2' and '8' at the same time, and then ' $\otimes$ ' key in sequence to start service mode.
- 2) Make the following selections:  
COPIER>FUNCTION>INSTALL>STRD-POS;  
then, press the OK key to execute auto adjustment.
- 3) When done, end service mode.

#### 4-5 Adjusting the Horizontal Registration

This horizontal registration may be adjusted by either of the following two ways:

- Using service mode of the host machine
- Adjusting the position of the side guide plate of the DADF pickup tray



It is easier to use service mode of the host machine.

- 1) Select the A4 or LTR Test Chart supplied according to a paper size to be used by a user.

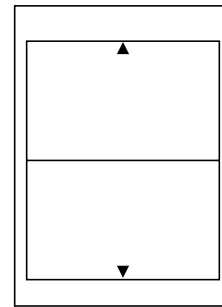

**Figure 4-9**

- 2) Place the test chart [1] on the original pickup tray, and make a print in Direct.

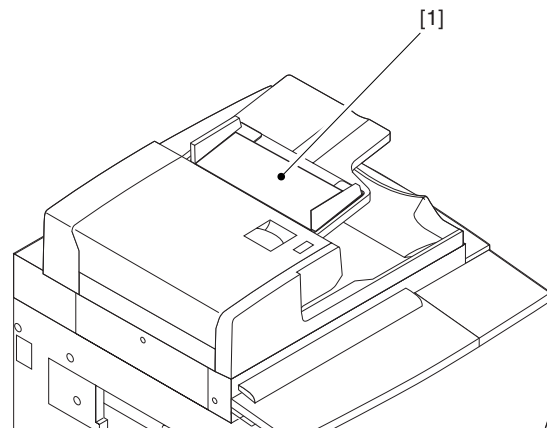
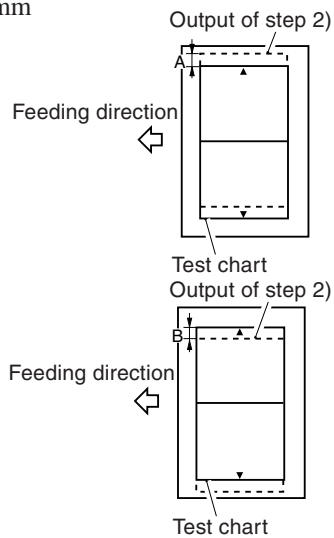

**Figure 4-10**

- 3) Put the test chart over the output obtained in step 2), and check to make sure that the following is true:

$$A \leq 1 \text{ mm}$$

$$B \leq 1 \text{ mm}$$



**Figure 4-11**

If the Horizontal Registration Is Not as Indicated

- a. Using Service Mode of the Host Machine

- 1) Press the ' $\otimes$ ' key, '2' and '8' at the same time, and ' $\otimes$ ' key in sequence to start service mode.
- 2) Make the following selections:  
COPIER>ADJUST>ADJ-XY>ADJ-Y-DF; then, change the settings to adjust.

A higher setting will increase A, while decreasing B.

Unit: 0.1 mm

Range: 100 to 400

- 3) Once again, print the test chart to make sure that the image is as indicated.

- b. Adjusting the Position of the Side Guide Plate of the DADF

- 1) Remove the three mounting screws [1], and detach the cover [2].

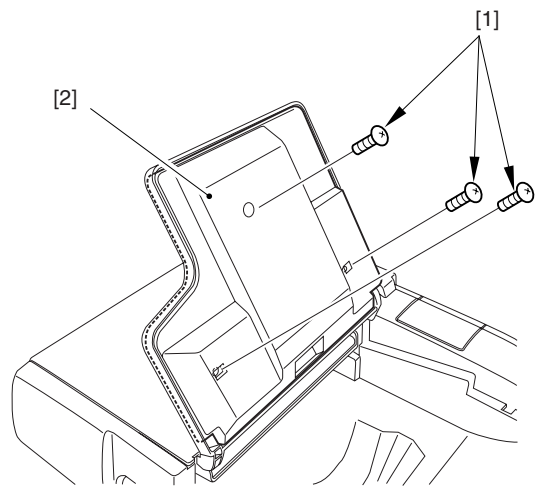

**Figure 4-12**

- 2) Loosen the mounting screw [1], and remove the screw [2] from the positioning hole, and fit it temporarily in the adjusting long hole [3].
- 3) Move the original width volume unit [4] to the front or the rear to adjust.

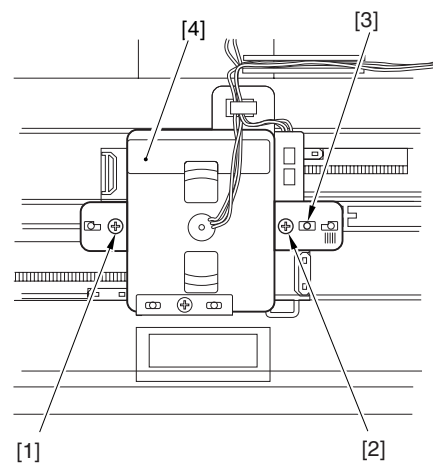

**Figure 4-13**

- 4) Tighten the screw [3] fitted to the adjusting long hole [2] and the temporarily tightened screw [1].
- 5) When done, mount the cover (Figure 4-12 [2]).
- 6) Once again, print the test chart, and check to make sure that the image is as indicated.
  - If  $A > 1$  mm, move the volume unit [4] to the front.
  - If  $B > 1$  mm, move the volume unit [4] to the rear.

#### 4-6 Adjusting the Read Speed

The read speed may be adjusted by either of the following ways:

- Using service mode of the host machine
- Using the ADF controller PCB



It is easier to use service mode of the host machine.

- 1) Select the A4 or LTR Test Chart supplied according to a paper size to be used by a user.

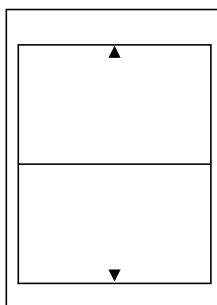

Figure 4-14

- 2) Place the test chart [1] on the original pickup tray, and make a print in Direct.

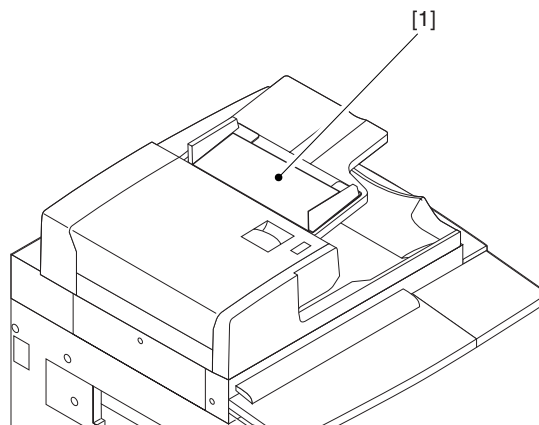

Figure 4-15

- 3) Place the test chart over the output of step 2 to make sure that the following is true in relation to dimension A of the test chart:

$$A \leq 1 \text{ mm}$$

$$B \leq 1 \text{ mm}$$

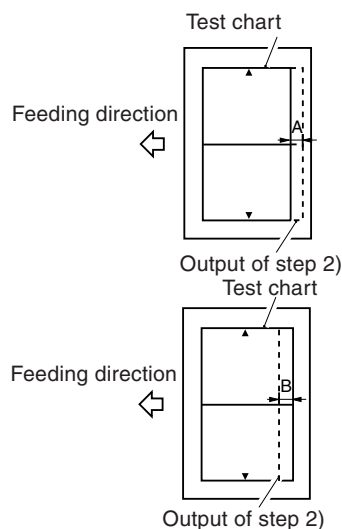

Figure 4-16



**If the Reading Speed Is Not as Indicated**

**a. Using Service Mode of the Host Machine**

- 1) Press the '⊗' key, '2' and '8' at the same time, and '⊗' key in sequence to start service mode.
- 2) Make the following selections: FEEDER>ADJUST>LA-SPEED; then, change the settings to adjust.

An increase by +1 increases the speed by 0.1%, decreasing A while increasing B.

Unit: 0.1%

Range: -30 to 30; -3% to 3%

- 3) Once again, make a print of the test chart to make sure that the image is as indicated.

**b. Using the ADF Controller PCB**

- 1) Remove the screw [1], and detach the ADF controller cover [2].

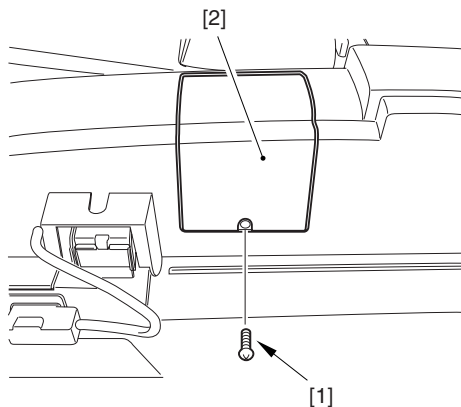

**Figure 4-17**

- 2) Set the DIP switch (DSW1) on the ADF controller PCB as shown in Figure 4-18, and press the push switch (PSW1) to start read speed adjustment mode.

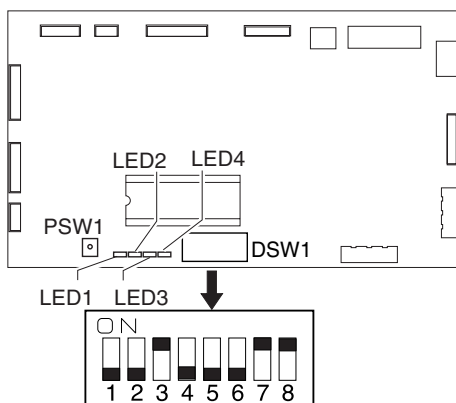

**Figure 4-18**

When read speed adjustment mode starts, the LEDs (Figure 4-18) on the ADF controller PCB indicate the present settings as follows:

The setting is indicated by LED1 (upper order) and LED4 (lower order) in 4-digit binary notation; a positive value is indicated when the LED remain ON, while a negative value is indicated when the LED flashes.

Figure 4-19 shows how LEDs behave to express '-26'.

1. All LEDs remain ON for 2 sec (start of indication).
2. All LEDs remain OFF for 1 sec.
3. The 10's place of the setting is indicated for 1 sec.
4. All LEDs go OFF.
5. The 1's place of the setting is indicated for 1 sec.
6. All LEDs remain OFF for 1 sec.

Note: If the setting is a negative value, the LEDs flash for both 10's and 1's places.

● :ON    ⊙ :flashes    ○ :OFF

Setting	LED			
	1	2	3	4
+10	●	○	●	○
+9	●	○	○	●
+8	●	○	○	○
+7	○	●	●	●
+6	○	●	○	○
+5	○	●	●	●
+4	○	●	○	○
+3	○	○	●	●
+2	○	○	●	○
+1	○	○	○	●
0	○	○	○	○
-1	○	○	○	⊙
-2	○	○	⊙	○
-3	○	○	○	⊙
-4	○	○	⊙	○
-5	○	○	⊙	⊙
-6	○	○	⊙	○
-7	○	○	⊙	⊙
-8	○	○	⊙	○
-9	○	○	⊙	⊙
-10	○	○	⊙	○

**Figure 4-19**

3) Enter the setting of the original feed speed using the DIP switch (DSW1) on the ADF controller PCB. (See Figure 4-20.)

The setting is entered in binary notation; if OFF, bit 1 indicates a positive value (+); if ON, bit 1 indicates a negative value (-).

- The range of adjustment is  $\pm 30$ .
- An increase of +1 increases the speed by 0.1%.

□ :switch OFF ■ :switch ON

Setting	bit 1 2 3 4 5 6 7 8	Setting	bit 1 2 3 4 5 6 7 8
+1	□□□□□□■	-1	■□□□□□■
+2	□□□□□□■□	-2	■□□□□□■□
+3	□□□□□□■■	-3	■□□□□□■■
+4	□□□□□■□□	-4	■□□□□□□□
+5	□□□□□■□■	-5	■□□□□□□■
+6	□□□□□■□□	-6	■□□□□□■□
+7	□□□□□■■□	-7	■□□□□□■□
+8	□□□□■□□□	-8	■□□□■□□□
+9	□□□□■□□■	-9	■□□□■□□■
+10	□□□□■□■□	-10	■□□□■□■□
+11	□□□□■□■■	-11	■□□□■□■■
+12	□□□□■□□□	-12	■□□□■□□□
+13	□□□□■□■□	-13	■□□□■□■□
+14	□□□□■□■□	-14	■□□□■□■□
+15	□□□□■□■■	-15	■□□□■□■■
+16	□□□■□□□□	-16	■□□■□□□□
+17	□□□■□□□■	-17	■□□■□□□■
+18	□□□■□□■□	-18	■□□■□□■□
+19	□□□■□□■■	-19	■□□■□□■■
+20	□□□■□□□□	-20	■□□■□□□□
+21	□□□■□□□■	-21	■□□■□□□■
+22	□□□■□□■□	-22	■□□■□□■□
+23	□□□■□□■■	-23	■□□■□□■■
+24	□□□■□□□□	-24	■□□■□□□□
+25	□□□■□□□■	-25	■□□■□□□■
+26	□□□■□□■□	-26	■□□■□□■□
+27	□□□■□□■■	-27	■□□■□□■■
+28	□□□■□□□□	-28	■□□■□□□□
+29	□□□■□□□■	-29	■□□■□□□■
+30	□□□■□□■□	-30	■□□■□□■□

Figure 4-20

4) Press the push switch (PSW1) to store the new setting, upon which the LEDs will go OFF. If the LEDs start to flash or remain ON, enter the setting once again. (See Figure 4-21.)

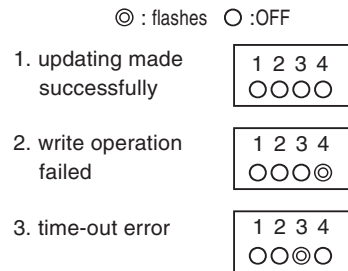

Figure 4-21

- 5) Press the push switch (PSW1) to end read speed adjustment mode.
- 6) Once again, print the test chart to make sure that the image is as indicated.
- 7) When done, shift all bits of the DIP switch (DSW1) on the ADF controller PCB to OFF.

#### 4-7 Adjusting the Leading Edge Registration

The leading edge registration may be adjusted by either of the following two ways:

- Using service mode of the host machine
- Using the ADF controller PCB



It is easier to use service mode of the host machine.

- 1) Select the A4 or LTR Test Chart supplied according to a paper size to be used by a user.

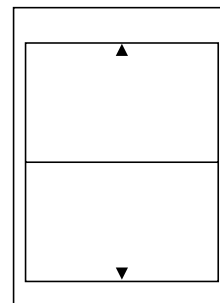
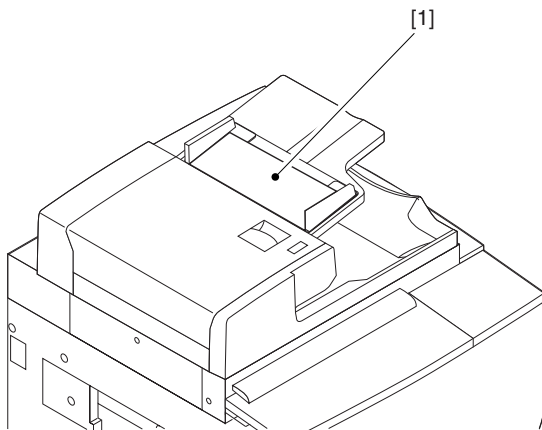

Figure 4-22

- 2) Place the test chart [1] on the original pickup tray, and make a print in Direct.



**Figure 4-23**

- 3) Check to make sure that the leading edge registration is as indicated with reference to dimension A of the test chart.  
 $A \leq 1 \text{ mm}$   
 $B \leq 1 \text{ mm}$

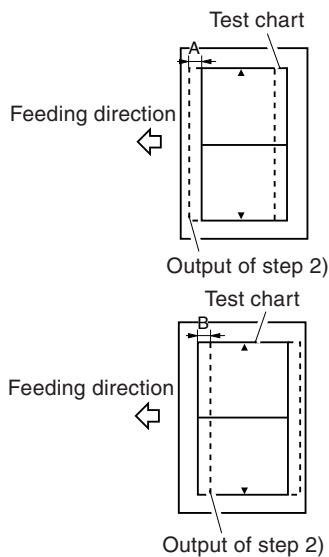

**Figure 4-24**

#### If Not As Indicated

- a. Using Service Mode of the Host Machine
  - 1) Press the '⊗' key, the '2' and '8' keys at the same time, and then the '⊗' key to start service mode.
  - 2) Make the following selections:  
 Feeder>ADJUST>DOCST; then, change the settings to make adjustments.

A change by +1 delays the output timing of the image leading edge signal by 0.5 mm, increasing margin A while decreasing margin B.

unit: 0.5 mm

range: -10 to 10; -5 to +5 mm

- 3) Once again, print the test chart to make sure that the image is as indicated.

#### b. Using ADF Controller PCB

- 1) Remove the screw [1], and detach the ADF controller cover [2].

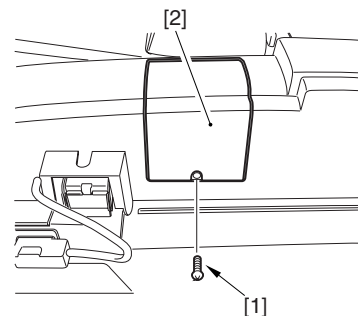

**Figure 4-25**

- Set the DIP switch (DSW1) on the ADF controller PCB as shown in Figure 4-26; then, press the push switch (PSW1) to start leading edge registration adjustment mode.

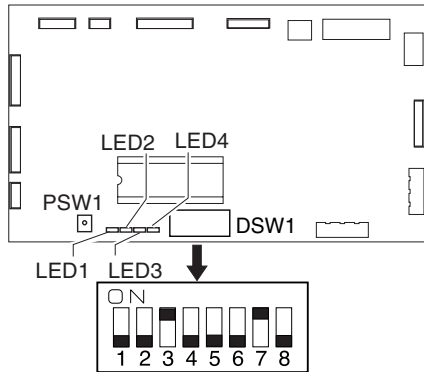

**Figure 4-26**

When leading edge registration adjustment mode starts, the LEDs (Figure 4-26) on the ADF controller PCB show the present setting. LED1 indicates the upper order while LED4 shows the lower order in 4-digit binary notation; the LEDs remain ON to indicate a positive value (+), while they flash to indicate a negative value (-).

< Sample Settings Indication >

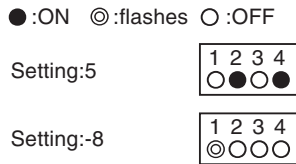

**Figure 4-26-1**

- Enter the setting of the leading edge registration using the DIP switch (DSW1) on the ADF controller PCB. (See figure 4-27.) The input must be in binary notation; further, bit 1 remains OFF to indicate a positive value (+), while it remains ON to indicate a negative value (-).

- Range:  $\pm 10$
- An increase of +1 delays the output timing of the image leading edge signal of an equivalent of 0.5 mm.

□ :switch OFF    ■ :switch ON

Setting	bit								Setting	bit							
	1	2	3	4	5	6	7	8		1	2	3	4	5	6	7	8
+1	□	□	□	□	□	□	□	■	-1	■	□	□	□	□	□	□	■
+2	□	□	□	□	□	□	■	□	-2	■	□	□	□	□	□	■	□
+3	□	□	□	□	□	■	■	□	-3	■	□	□	□	□	■	■	□
+4	□	□	□	□	■	□	□	□	-4	■	□	□	□	■	□	□	□
+5	□	□	□	■	□	□	■	□	-5	■	□	□	□	■	□	□	■
+6	□	□	□	■	■	□	□	□	-6	■	□	□	□	■	□	□	□
+7	□	□	□	■	■	■	□	□	-7	■	□	□	□	■	■	■	□
+8	□	□	■	□	□	□	□	□	-8	■	□	□	■	□	□	□	□
+9	□	□	■	□	□	■	□	□	-9	■	□	□	■	□	□	■	□
+10	□	□	■	□	■	□	□	□	-10	■	□	□	■	□	□	■	□

**Figure 4-27**

- Press the push switch (PSW1) to store the new setting, upon which the LED go OFF. if the LEDs flash or remain ON, enter the setting once again. (See Figure 4-28.)

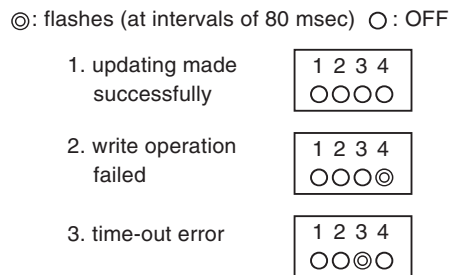

**Figure 4-28**

- Press the push switch (PSW1) to end read leading edge registration adjustment mode.
- Once again, make a print of the test chart to make sure that the image is as indicated.
- When done, shift all bits of the DIP switch (DSW1) on the ADF controller PCB to OFF.